

SMARTELEC²

ENERGY SAVING CONTROL

INSTALLATION AND OPERATING MANUAL



INDEX	Section
General information	1
Dimensions & Technical Specification	2
Factory Supplied Wiring	3
Installer Wiring Details	4
Installation Details	5
User Instructions	6
Fault Indicators	7
Servicing	8

WARNINGS

- 1 This appliance must only be installed by a competent person in accordance with the requirements of the Codes of Practice or the rules in force.
- 2 All external wiring MUST comply with the current IEE wiring regulations.
- 3 This appliance must be earthed.

1. General Information.

Introduction

This instruction manual describes the SmartElec control that can be fitted to the Airbloc electric air curtains.

This control is exclusive to Airbloc and as such the instructions detailed in this manual must be followed to ensure safe and reliable operation.

The SmartElec control can be used with 9,12,18 and 24kW Airbloc air curtains.

The SmartElec consists of a base unit (installed within the air curtain) and a program panel that can be installed remote from the air curtain.



The factory fitted base unit shown above provides terminals for 3 phase + neutral supply connection and low voltage program panel wires.

The SmartElec base unit rapidly pulses energy to the heating elements. This combined with the inbuilt intelligent sensor control, maintains a fixed outlet temperature, thereby reducing energy consumption when compared to an air curtain without the SmartElec control. For further information detailing the potential energy savings of the SmartElec, please contact Airbloc direct. (contact details on the back of this manual.)

Usually, the program panel is mounted at low level from the air curtain for user access and up to a maximum distance of 110m. The base unit and program panel are linked by a low voltage cable as specified in these instructions.



The program panel shown opposite allows the user to control either a single air curtain, or a network of up to 16 air curtains, & provides the following functions:

- Heat on or off.
- Off or low, medium and high fan speeds.

For full details of all functions please refer to section 6, User instructions, in this manual.

General

All installations must be in accordance with the regulations in force in the country of use.

These instructions must be handed to the user on completion of the installation.

Installers and service engineers must be able to demonstrate competence and be suitably qualified in accordance with the regulations in force in the country of use.

To ensure continued and safe operation it is recommended that the appliance is serviced annually.

The manufacturer, offers a maintenance service. Details are available on request.

Electrical

This appliance must be earthed.

It is recommended that the electrical supply to the SmartElec base unit is via an appropriate 4 pole isolator in accordance with the regulations in force in the country of use, and must have a minimum contact separation of 3mm on all poles.

Electrical supply is 415V 3 phase, neutral and earth. Max cable inlet size is 10mm².

Remote unit is wired to the base unit via a 4 core factory supplied screened cable.

Networked air curtain interconnects are via a 4 core factory supplied screened cable.

Fixing details

The SmartElec base unit is pre-installed inside the air curtain unit.

The SmartElec program panel is a separate unit and can be either surface mounted or flush wall mounted.

The distance between the base unit and the program panel can be up to 110m maximum.

Health and safety

Sole liability rests with the installer to ensure that all site safety procedures are adhered to during installation, including the use of personal protective equipment.

Do not rest anything, especially ladders, against the product.

Standards

Units conform to the European electrical standard BS EN 60335-2-30, and to the following European CE directives: 73/23/EEC low voltage, 89/336/EEC and 98/68/EEC electromagnetic compatibility.

2. Dimensions & Technical Specification.

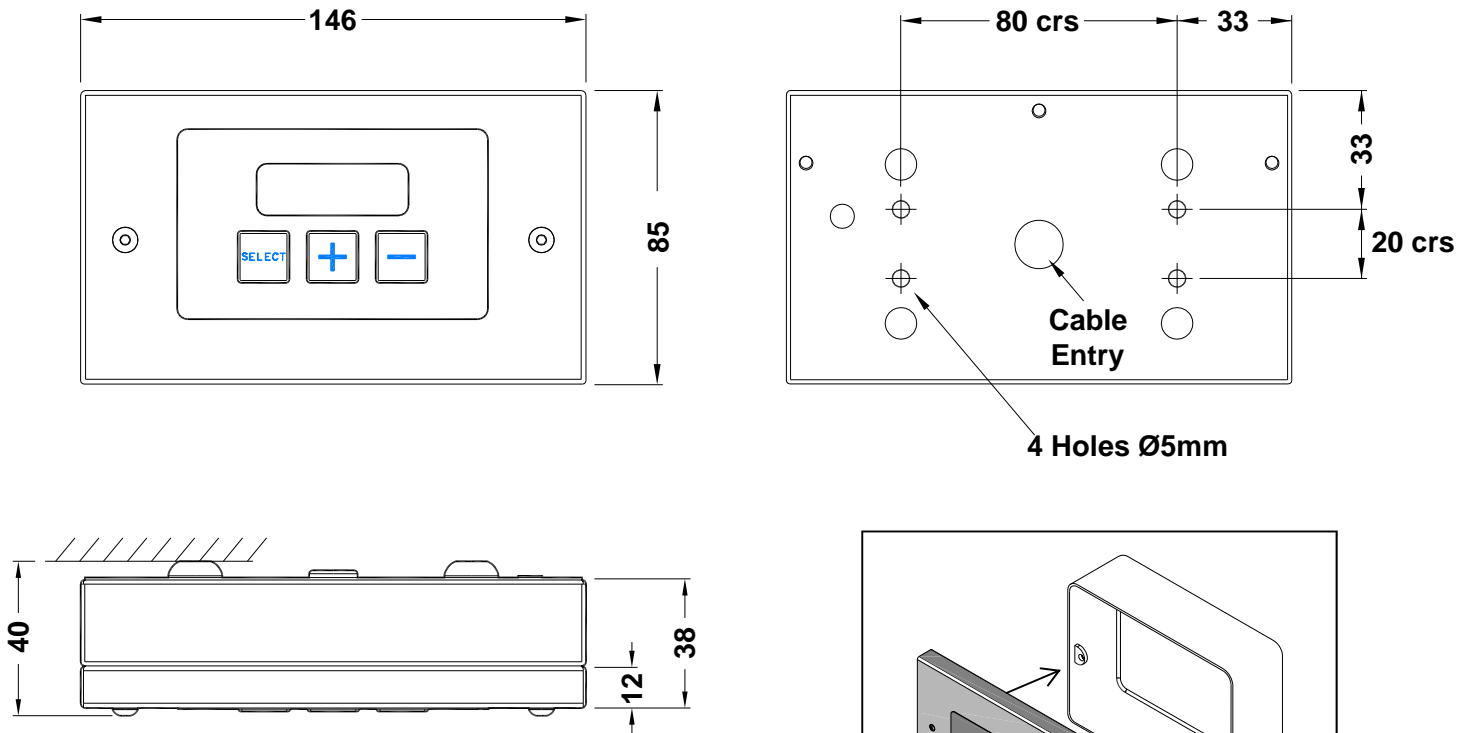

Figure 1. Dimensions (mm) program panel (surface mount shown, factory supplied).

Technical specification.

Sensor input	NTC
Control setpoint	16°C to 35 °C in steps of 1 °C
Temperature control	PID
Minimum power	3%
Maximum power	97 %
Cycle time	0.9 second fixed
Protection	2 x fuses for the protection of the heater switching thyristors
Fan output	3 off relays for high, medium and low fan setting 3A max 240Vac
Connections	Screw terminals 4 for supply, 3 for heater output, 4 for fan output, 2 for sensor input, 2 for external thermal trip, 2 for door switch, 2 for external sensor, 2 for BMS
Supply	415 V rms +/-15% 50Hz. Electronics 1.5VA max.
Dimensions	Program panel 146mm(L) x 85mm(W) x 38mm(H) max.
Mounting positions	Program panel fixing centres 80mm x 20mm
Temperature	0°C to 40 °C operating temperature
Display	Triple 7 segment red LCD for parameter display
Push buttons	3 positive feedback tactile push buttons

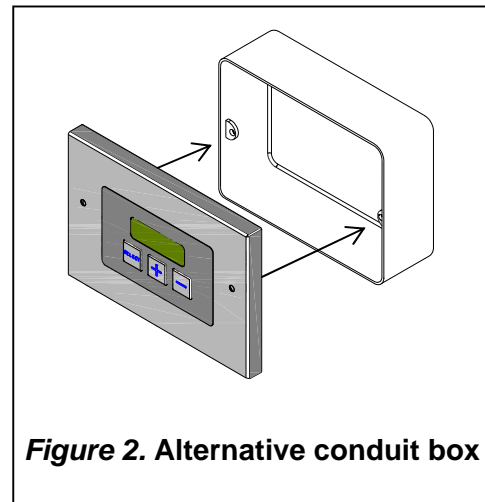
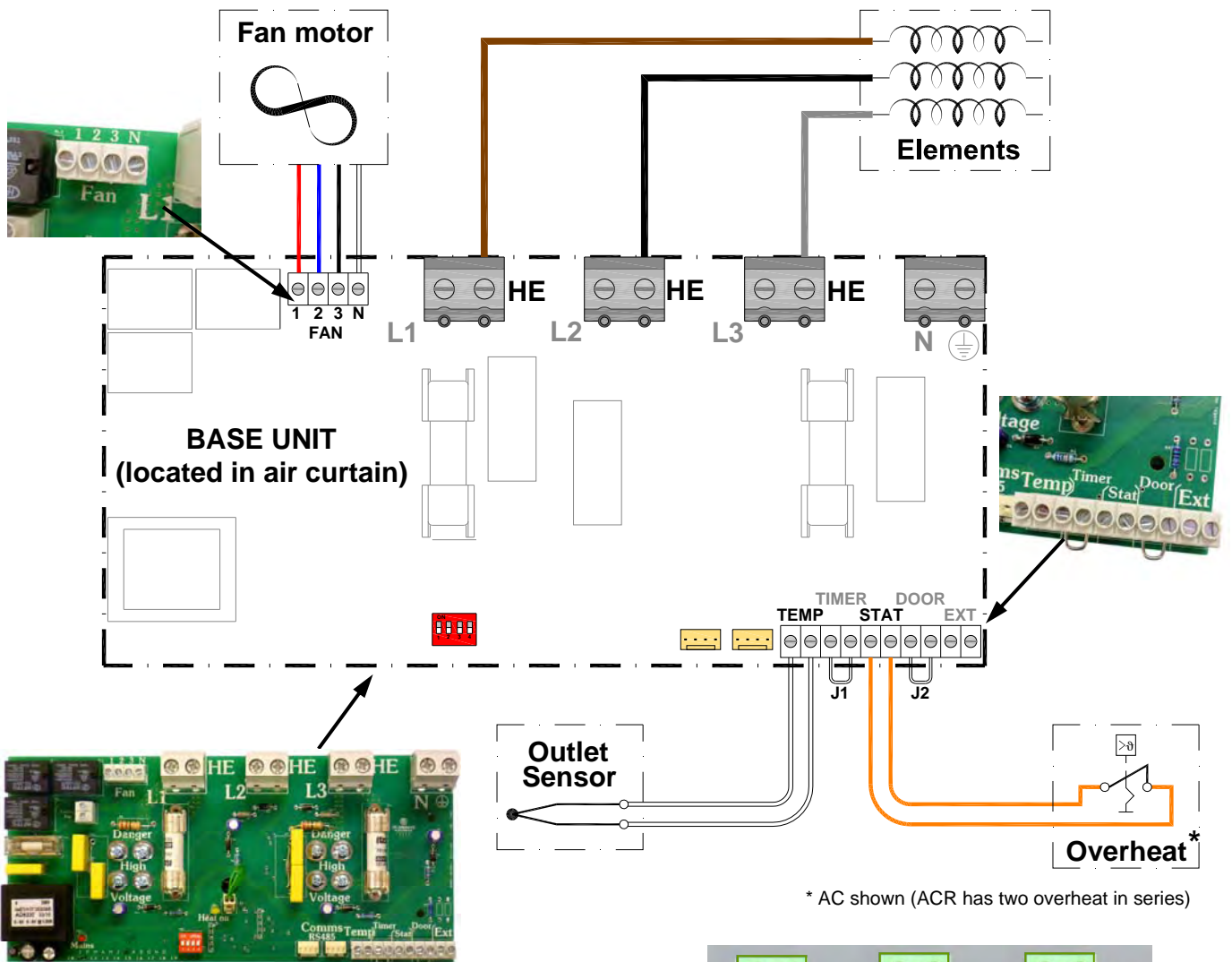

Figure 2. Alternative conduit box

3. Factory Supplied Wiring.



* AC shown (ACR has two overheat in series)

Terminal	Description	Cable
HE	Heating elements phase 1	10mm ² max
HE	Heating elements phase 2	10mm ² max
HE	Heating elements phase 3	10mm ² max
N	Neutral to fan	1.5mm ² max
1	Fan - low speed	1.5mm ² max
2	Fan - medium speed	1.5mm ² max
3	Fan - high speed	1.5mm ² max
Temp	Air sensor pair (non-polarised)	1.5mm ² max
Stat	Ext thermal trip pair, n.c. (volt-free)	1.5mm ² max
Comms	Keypad/network connectors	Pre-wired

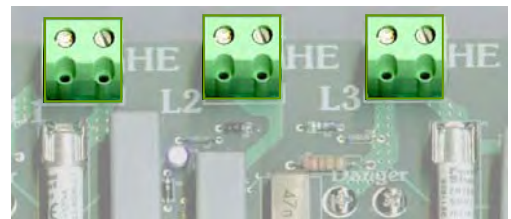

The heater element outputs are connected to the right hand side of three terminal blocks and are marked 'HE'. (See below).

The fan output is connected to a 4 way terminal block marked 'N, 1, 2 and 3'.

The sensor input (air sensor) is connected to 2 terminals marked 'TEMP' on the base unit. The sensor is not polarity sensitive.

The external thermal trip (volt-free) is connected to 2 terminals marked 'STAT' on the base unit. The terminals are not polarity sensitive.

4. Installer Wiring Details.

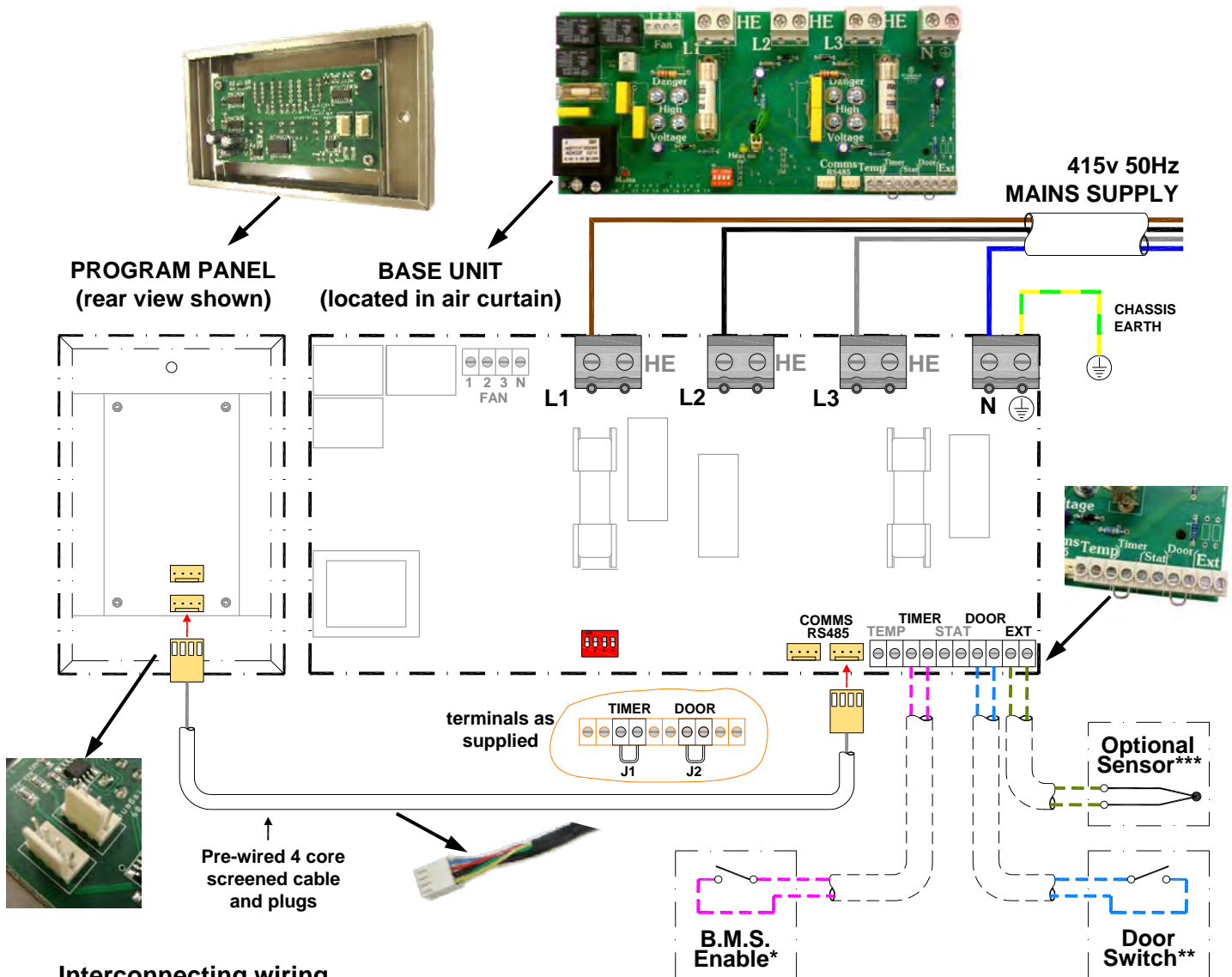

Interconnecting wiring

The program panel is connected to the base unit via a set of pre-wired 4 core screened cables with pre-wired plugs as shown.

Interconnecting wiring is via a 4 core screened cable with pre-wired plugs, supplied in 2, 10, 20, 30, 50 and 100m lengths.

It is recommended that this control cable is run separately within its own trunking to avoid external interference.

Optional wiring

* **External switch** (ie BMS enable) to be volt free and wired via normally open contacts to terminal pair 'TIMER'. (Contacts closed to enable). Remove factory fitted jumper J1.

** **Door switch** to be volt free and wired via normally closed contacts to terminal pair 'DOOR'. (Contacts open to enable door mode). Remove factory fitted jumper J2. refer section 6.6.1 - Door link settings.

*** **Internal/external sensor** to be wired to terminal pair 'EXT'. refer section 6.6.4 - External Temperature.

Protection

There are two high speed fuses on the base unit to protect the switching thyristors for the heater. An external circuit breaker with the appropriate rating should be installed for the protection of the installation.

Terminal	Description	Cable
N	Neutral	10mm ² max
L1	3 phase supply	10mm ² max
L2	3 phase supply	10mm ² max
L3	3 phase supply	10mm ² max
E	Mains earth	10mm ² max
Timer*	BMS pair (volt -free)	1.5mm ² max
Door**	Door interlock pair, n.c. (volt free)	1.5mm ² max
Ext***	External sensor pair (non-polarised)	1.5mm ² max

Network Wiring Electrically Heated with SmartElec2 Control.

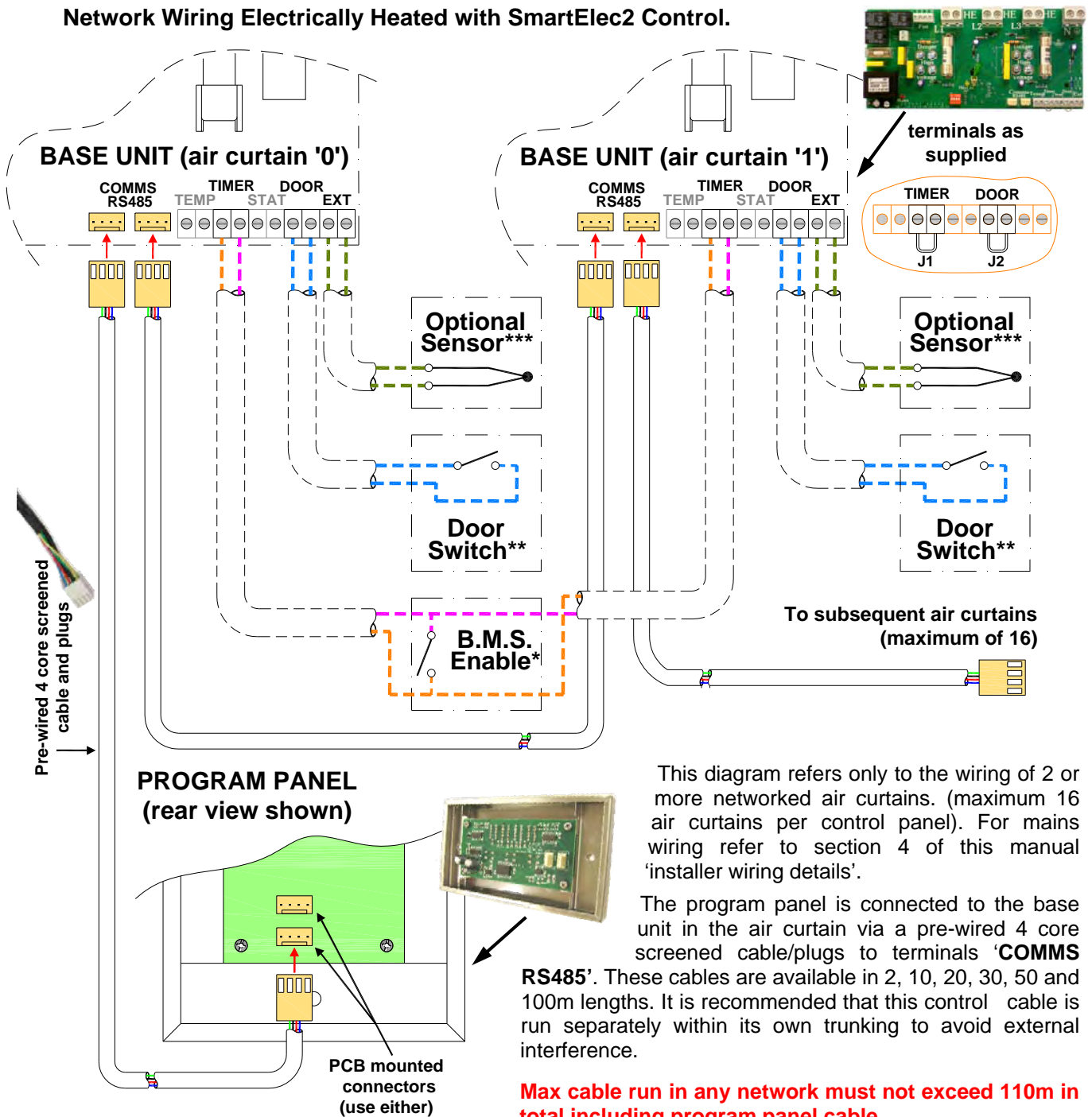

Note: All air curtains connected within the network system will operate under the settings of the single keypad.

Any air curtain within the network can be connected with and respond to the following optional circuits:

* **External switch** (ie BMS enable) where required, to be volt free and wired **in PARALLEL** via normally open contacts to each terminal pair 'TIMER'. (Contacts closed to enable). Only air curtain(s) wired this way will respond to the enable signal. Remove factory fitted jumpers J1. **NOTE: terminals are polarity sensitive**

** **Door switches** where required, to be volt free and wired to **INDIVIDUAL** base units via normally closed contacts to each terminal pair 'DOOR'. (Contacts open to enable door mode). Only air curtain(s) wired this way will respond to the door mode. Remove factory fitted jumper J2. refer section 6.6.1 - Door link settings.

*** **Internal/external sensors**, where required, to be wired to **INDIVIDUAL** base units to each terminal pair 'EXT'. Only air curtain(s) wired this way will respond to the sensor setting. If a sensor is fitted to more than one air curtain then the value is displayed as an average. refer section 6.6.4 - External temperature.

5. Installation Details.

The SmartElec base unit is pre-installed inside the air curtain. All the external electrical connections are via screw terminals and plug/socket onto this base unit.

The SmartElec program panel is installed in a separate housing and surface mounted in a suitable location. Please see figure 3a.

Figure 3a. Surface mount location holes.

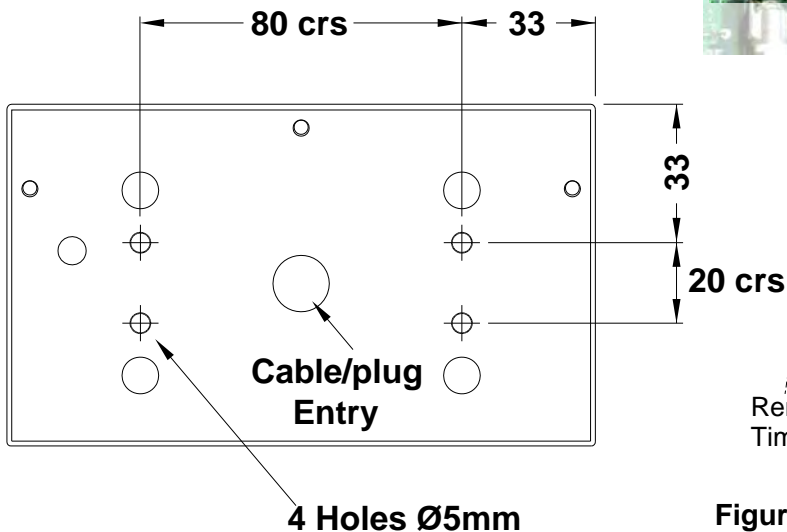

Alternatively, the program panel can be flush wall mounted with the addition of a standard double gang conduit box. Please see figure 3b.

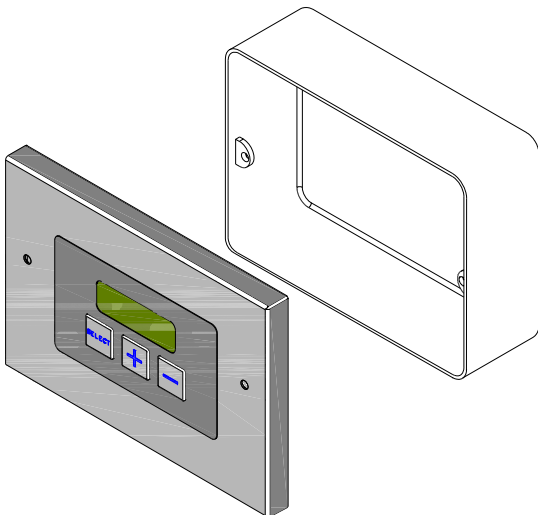

Figure 3b. Alternative rear conduit box.

The cable distance between the base unit and the program panel can be up to 110m.

The total cable distance between networked air curtains can be up to 110m. (First to last air curtain, plus program panel)

3 Phase mains supply

The 3 phase mains supply is connected to the terminals marked 'L1' 'L2' & 'L3' and the neutral is connected to the terminals marked 'N'. The **earth terminal** is marked with the earth symbol.

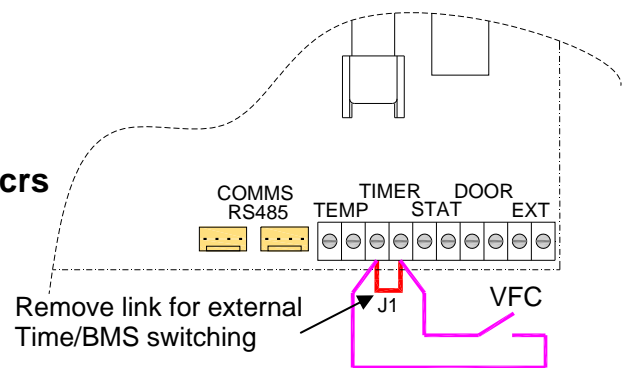

Figure 4. External time/BMS switching

External time/BMS switching

Each air curtain comes complete with a pair of external terminals for on/off or timed operation. To utilise this facility, simply remove the jumper cable J1 between the TIMER terminals and connect to an external switching source*.

** please note: external switch must be volt free.*

Multi external time/BMS switching

If a single external switch is required on a network of 2 or more air curtains, this can be achieved by using the BMS connection on one (master) air curtain, then using the link group interlock setting as described in section 6.6.2. Using this method all air curtains in the network will respond to the signal from the master air curtain.

6. User Instructions.





fig.5. SmartElec2 Programmer

6.1 Keypad buttons





The buttons have the following functions:

-  Press the select button to allow navigation.
-  Press the + button to increase a setting.
-  Press the - button to decrease a setting.

6.2 Keypad display

6.2.1 Normal mode displays

Display	Meaning
	First power up
	No air curtains found
	Curtain address and temperature set point

6.2.2 Normal Operation

During normal operation mode the display is dimmed.

Pressing the  button, will put the panel into active mode. If no button is pressed for several seconds the display reverts to normal mode.

During normal operation the unit will display for example:

 where '0' is the curtain address, and '25' the temperature measured for the unit.

Where multiple air curtains exist in a network, the display scrolls through each unit in turn, changing approximately once every second.

If the air curtain is in operation and under heat demand, a 'decimal point' is shown after the air curtain address.



6.3 OFF mode.

During normal operation, press and hold the  button for approximately two seconds. The display blanks until you release the button. The heating and fans are now turned off. Releasing the button in less than this time and the action has no effect.



Where multiple air curtains exist in a network, this action turns off all air curtains.

6.4 Settings Mode

6.4.1 Activate settings display

To enter the Settings mode press the  button. This will illuminate the screen. Press the  button till the desired setting is shown.

By pressing the  button it will also advance to the next setting.

Note: If a setting has been altered by using the  or  buttons, it must be confirmed by pressing the  button.

6.4.2 Settings displays

Press the  button to advance through the settings.

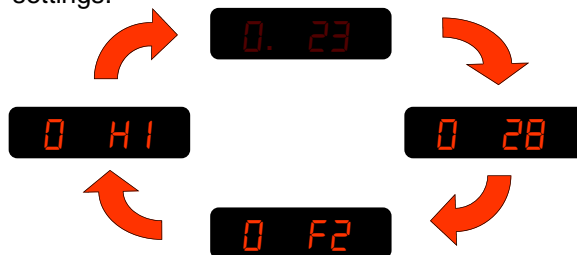

Where multiple air curtains exist in a network and controlled from a single keypad, these will be detected and displayed in turn, for example:



Any air curtain in the network can be accessed by pressing the  button when it's address appears on the display. The settings can then be accessed as previously described.

6.5 Set-up configurations

6.5.1 Set fan speed

Once the display becomes illuminated press the  button once. Display shows the fan speed.

Press  to increase fan speed.

Press  to decrease fan speed.

Three speeds and an 'off' setting are available:

 Speed 1  Speed 2

 Speed 3  Fan 'off'

6.5.2 Set heat

Press the  button again Display shows the heat setting.

Press  to set heat 'on'.

Press  to set heat 'off'.

If no button pressed for 2 seconds, display will revert to normal user. eg 

6.5.3 Set temperature

Press the  button once to allow changes to be made.

Press  to increase temperature set point.
(max 35°C)

Press  to decrease temperature set point.
(min 16°C)

Display shows for example: 

6.5.4 Networked air curtains

Where multiple air curtains exist in a network and controlled from a single keypad, these will be detected and displayed in turn, for example:











Any air curtain in the network can be accessed by pressing  when it's address appears on the display. The settings can then be changed as previously described.



6.6 Engineers settings

Other options are available in engineer's mode.

To access the engineers mode *either*:
press and hold the  button for a few seconds until the display goes blank, then press  briefly. The display will show 

or

Power-up the system with the  and  buttons pressed and release when the display goes blank the display will show 

As in normal mode, Engineers set-up mode is started by pressing the  button whereupon the display will illuminate. Advance through the normal modes settings of temperature, fan and heat by pressing the  button.





Pressing the  button again advances to further options to allow other settings of the system. The engineers set-up options listed herewith depend various factors e.g. optional door switch, multiple air curtains etc.

Notes: If a panel has never before been run, it automatically starts in engineer's mode when first powered-up.

Engineer's mode automatically self-clears after approximately 10 minutes of non-activity on the switches.

6.6.1: Door link settings:

This provides an alternative fan speed and heat setting which is activated only when the door link is open circuit.

The fan speed is accessed by pressing the  button until the display shows:  Use the  and  buttons to change the setting.

Display

Meaning



Fan off







Fan speed 1











Fan speed 2





Fan speed 3





The temperature setting when the door link is open circuit is accessed by pressing the  button until the display shows . Use the  and  buttons to alter the temperature value.

Display	Meaning
	Heat off
	5°C
	10°C
	15°C
	20°C
	25°C
	30°C
	35°C

6.6.2 Link-group interlock

If there is more than one air curtain, a group interlock option may be set. This provides an alternative fan speed and heat setting when activated by certain external connections on individual air curtains.



This function is accessed by pressing the  button until the display shows  (where '0' is the air curtain address to be used as a master unit for interlocks.)

Display	Meaning
	Default setting
 to 	Master setting range
	Other air curtains

See table below for possible settings.

Master setting	Function
1	Timer/BMS interlock
2	Door interlock
3	Timer/BMS/door interlock
4	Stat interlock
5	Timer/BMS/stat interlock
6	Stat/door interlock
7	Timer/BMS/stat/door interlock



6.6.3 All air curtains



This function is accessed by pressing the  button until the display shows .

Using this setting all air curtains in a network respond to the same settings. Settings for individual air curtains can still be changed if required.

6.6.4 External temperature

This is only displayed if the factory supplied optional external temperature sensor is connected to the air curtain.



This function is accessed by pressing the  button until the display shows .

Use the  and  buttons to change to the desired temperature setting.

If the external temperature is equal to the set temperature, all air curtains are turned off. The temperature must then drop to 3°C below the set temperature before the air curtains are turned back on.

Note: for multiple air curtains - more than one can have an external sensor connected. When this is the case the sensor values are displayed as an average. (If one external sensor goes faulty, the average is worked out from the remaining working ones).

6.6.5 External temperature offset

This function is accessed by pressing the  button until the display shows .

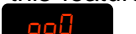

This setting allows the temperature setpoint to be automatically increased as the external temperature falls to, or below, zero. For instance, a setting of 4 means a +4°C offset at 0°C. The maximum offset is 9°C. If this feature is not required the setting should be .

Note: When more than one air curtain is used, this feature will only work under the 'all controllers' setting.

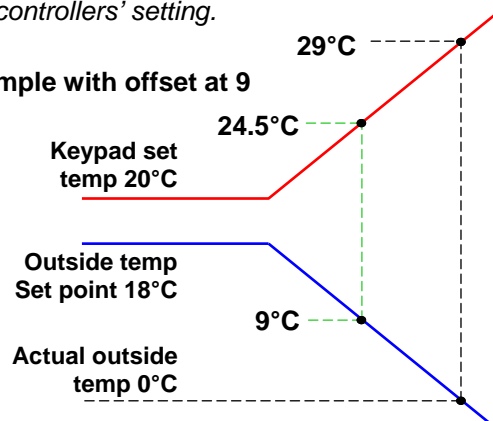
Example with offset at 9



6.6.6 Temperature limits

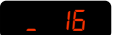

This function is accessed by pressing the  button until the display shows  and  respectively i.e. maximum and minimum set limits for set temperature.

Use the  and  buttons to change to the desired limit temperature settings.

The maximum (default 35°C) may be set anywhere between the current minimum and 50°C, and the minimum, (default 16°C) may be set anywhere between 3°C and the current maximum.



To exit the engineers mode press and hold the  button for a few seconds.

6.7 Power-up Manual Reset

The system can be reset by powering-up the panel whilst holding down the  and  buttons.

The display shows the 'start' pattern but then goes blank.

Release the buttons where upon the display resumes and the system addressing commences, finding only those air curtains which are actually connected and working.

If  appears on the display, press and hold the  button for a few seconds then release. The display will then return to the normal mode.

6.8 Air curtain addressing

All air curtains work on an address address to communicate with the keypad and are supplied with an default address of '0'.

Where multiple air curtains exist in a network they must be re-addressed using a unique address (0-9/A-F). This is achieved using a 4 way bitswitch mounted on the base unit PCB (see photo opposite)

The keypad will check all addresses on first power up and this is displayed as the first digit on the display (in a network set up, all addressees will be viewed in rotation).

Note: If any address is altered after initial power up or an air curtain removed after initial installation, the keypad will also retain the original address although unable to respond.

To remove this unwanted address(s) follow the details in 6.7 Power-up Manual Reset.

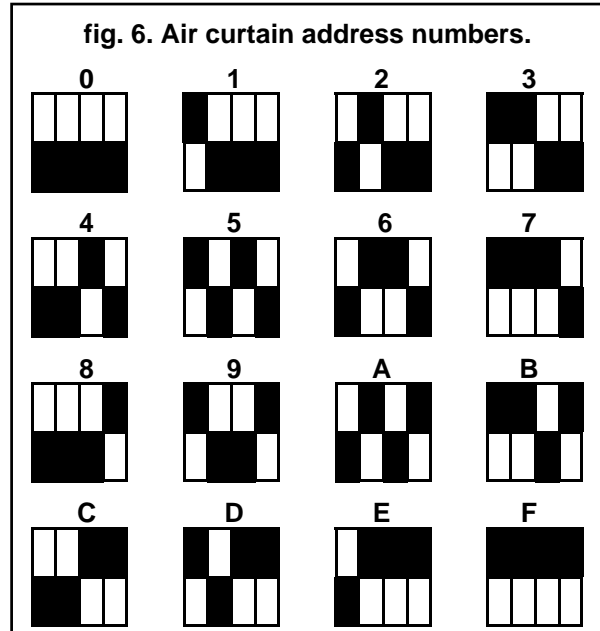
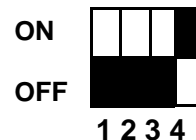

fig. 7. Bitswitch position



The black shaded areas represent the switch position.

The example shows the **ON** air curtain set to No.8.



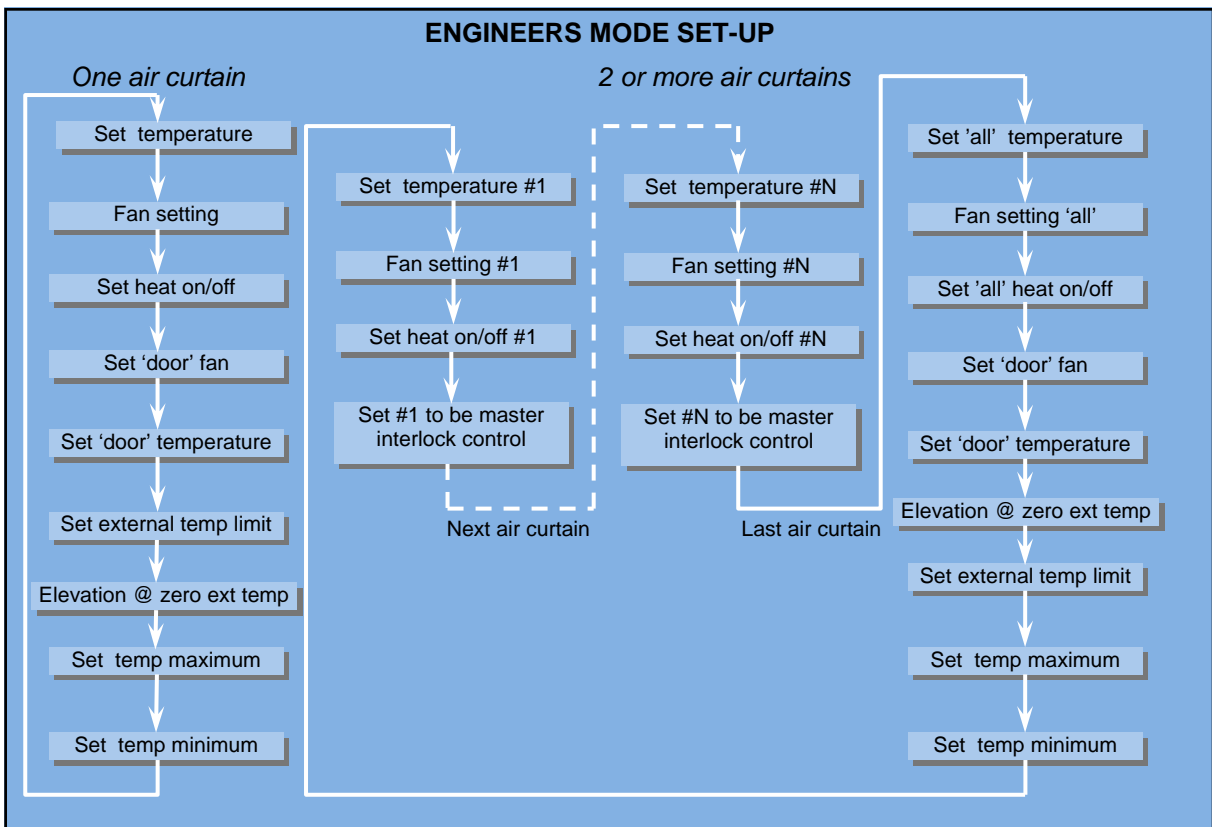
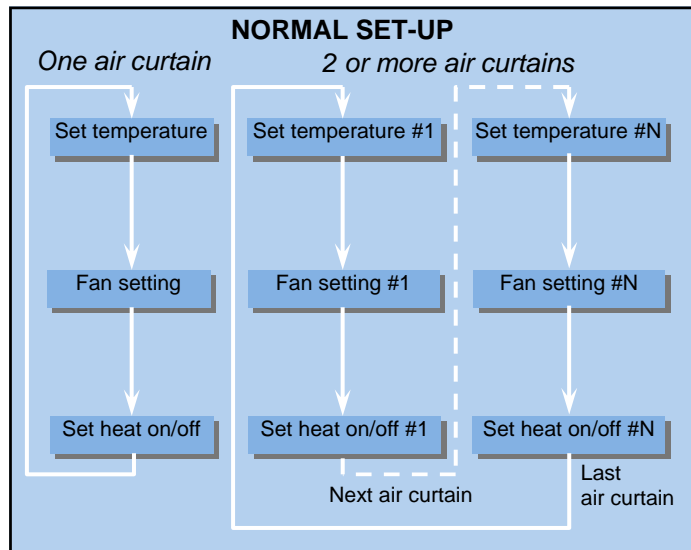
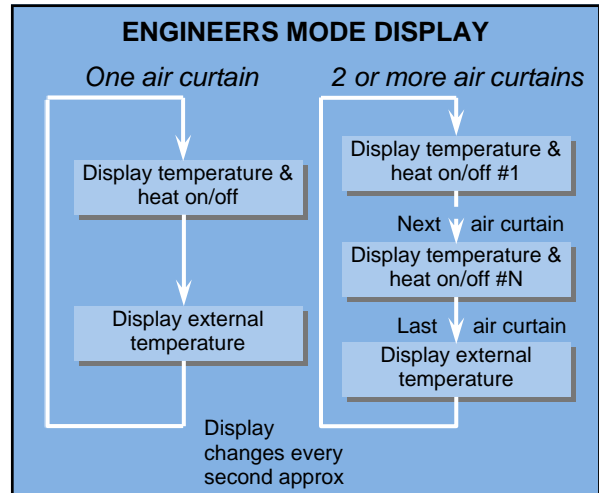
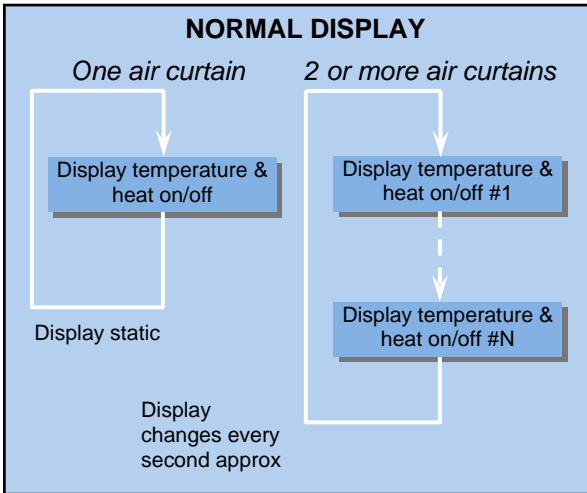

6.9 Keypad sequences



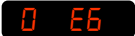

7. Fault Indicators.

The SmartElec2 control raises an alarm if any of its inputs are outside their normal working scope. Alarms are displayed on the program panel as a code with a prefix "E".  The first number represents the air curtain address. See chart over.

As the alarms are mutually exclusive, the first alarm code displayed on the program panel will stay on until the fault has been cleared.

Apart from the communication failure alarm  which could be due to a broken connection of the data link and air curtain not found alarm,  which could be due to incorrect addressing, all other alarms will cause the base unit to switch off the heater output.

The SmartElec2 base unit is protected from any short circuit on the air sensor  or heat sink sensor  as the error will cause the temperature to rise and trigger over temperature alarm. 

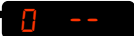
There are five basic checks to perform should  appear on the program panel display. These are as follows:

1: Continuity: Use a multimeter to check continuity between each end of all four cores at the plugs

2: Short circuit: Use a multimeter to check that there are no short circuits between any of the four cores.



N.B. This test should be done with both ends of the cable disconnected to avoid false readings.

3: Plugs: Check that the plugs are firmly seated on the circuit board pins in both the program panel and on the base unit.

4: Addressing: (Network versions only). If two or more air curtains are networked, check that each base unit has a unique address as described in section 12.4

5: Network cables: Ensure that the total run of all cables in the network does not exceed 110m including the cable to the program panel.

If a panel has never before been run, it automatically starts in engineer's mode when first powered-up. To exit this mode, press and hold the  Button. Alternatively, the engineer's mode automatically self-clears after approximately 10 minutes of non-activity on the switches.

The system can be reset by powering-up the panel whilst holding down the  and  buttons.

The display shows the 'start' pattern but then goes blank.

Release the buttons where upon the display resumes and the system addressing commences, finding only those air curtains which are actually connected and working.

7.1 SmartElec2 fault codes

*NOTE: '#' denotes the controller number.

Code	Description	Symptom	Possible cause	Remedy
#* _ _	COMMUNICATION FAILURE.	No control on faulty unit	Bad data cable connection Damaged cable	Check data cable(s) and plugs Repair/replace damaged cable
# E1	AIR SENSOR TEMPERATURE TOO HIGH or AIR SENSOR FAILURE.	Fan operating, no heat	High ambient air temperature	Check ventilation
			Impeller turning in wrong direction	Check rotation of impeller
		Fan operating, no heat	Motor failure	Check motor & replace if necessary
			Air sensor cable disconnected Air sensor broken	Check cable Replace air sensor
# E3	HEATSINK TOO HOT	Fan operating, no heat	High ambient air/faulty base unit	Replace SmartElec base unit
# E4	HEATSINK SENSOR FAILURE	Fan operating, no heat	Heatsink sensor wiring disconnected/faulty	Check wiring
			Heatsink sensor faulty	Replace SmartElec base unit
# E5	EXTERNAL TEMPERATURE SENSOR FAILURE	Unit runs, but no external temperature control	External temperature sensor faulty	Replace sensor
			External temperature sensor wiring faulty	Repair/replace faulty wiring
# E6	OVERHEAT THERMOSTAT OPEN CIRCUIT	Fan operating, no heat	Overheat thermostat open circuit	Reset/replace overheat thermostat

7. Fault Indicators cont.

SmartElec base unit LED indicator location/function:

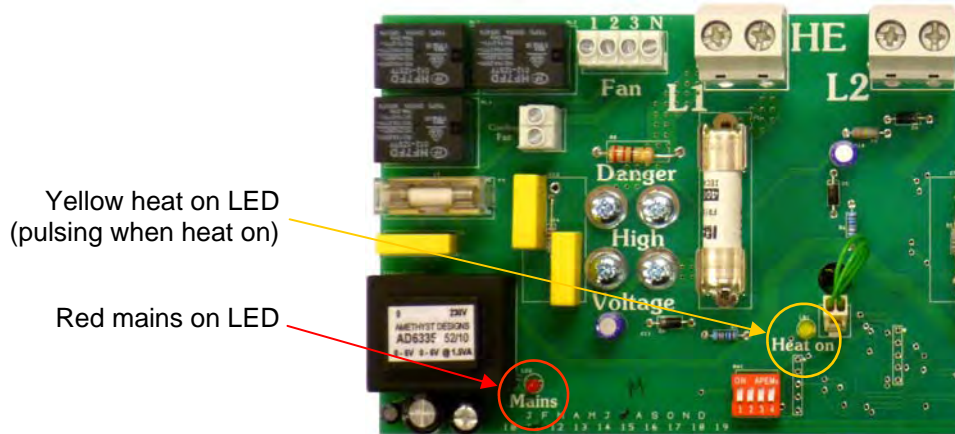

8. Servicing.

The air curtain should be serviced annually. Airbloc offer a service facility, call 01384 489700.

Servicing should only be undertaken by a competent person.









Any repair or alteration carried out to this product without the prior authority from AmbiRad will invalidate warranty.

Refer to air curtain Installation and operating instruction manual for details.

Ensure electrical power is isolated from the product before commencing any service work.

9. Spares & Accessories.

! Due to the nature of their construction, it is not advisable to attempt to repair damaged electronic components on either the SmartElec2 base unit or program panel.

	Description	9/12/18 kW models	24 kW models	Description	9/12/18 kW models	24 kW models
	Program Panel	108221			n/a	900330
	Panel P.C.B	SELEC2RP			SC-OS	
	Base Unit	SELEC2BU			2M SE2-CABLE-2 10M SE2-CABLE-10 20M SE2-CABLE-20 30M SE2-CABLE-30 50M SE2-CABLE-50 100M SE2-CABLE-100	
	Heat Sensor	SELEC2HS				
	Fuse	900471	900472			
	Control fuse	900473				



AmbiRad Limited Fens Pool Avenue
Brierley Hill West Midlands DY5 1QA
United Kingdom.

Telephone 01384 489700
Facsimile 01384 489707
Email info@ambirad.co.uk
Website www.airbloc.co.uk
Technical Support www.s-j-d.co.uk

 An AmbiRad Group brand

ENERGY SAVING AIR CURTAINS

AmbiRad and Airbloc are registered trademarks of AmbiRad Limited. Because of continuous product innovation, AmbiRad reserve the right to change product specification without due notice.